

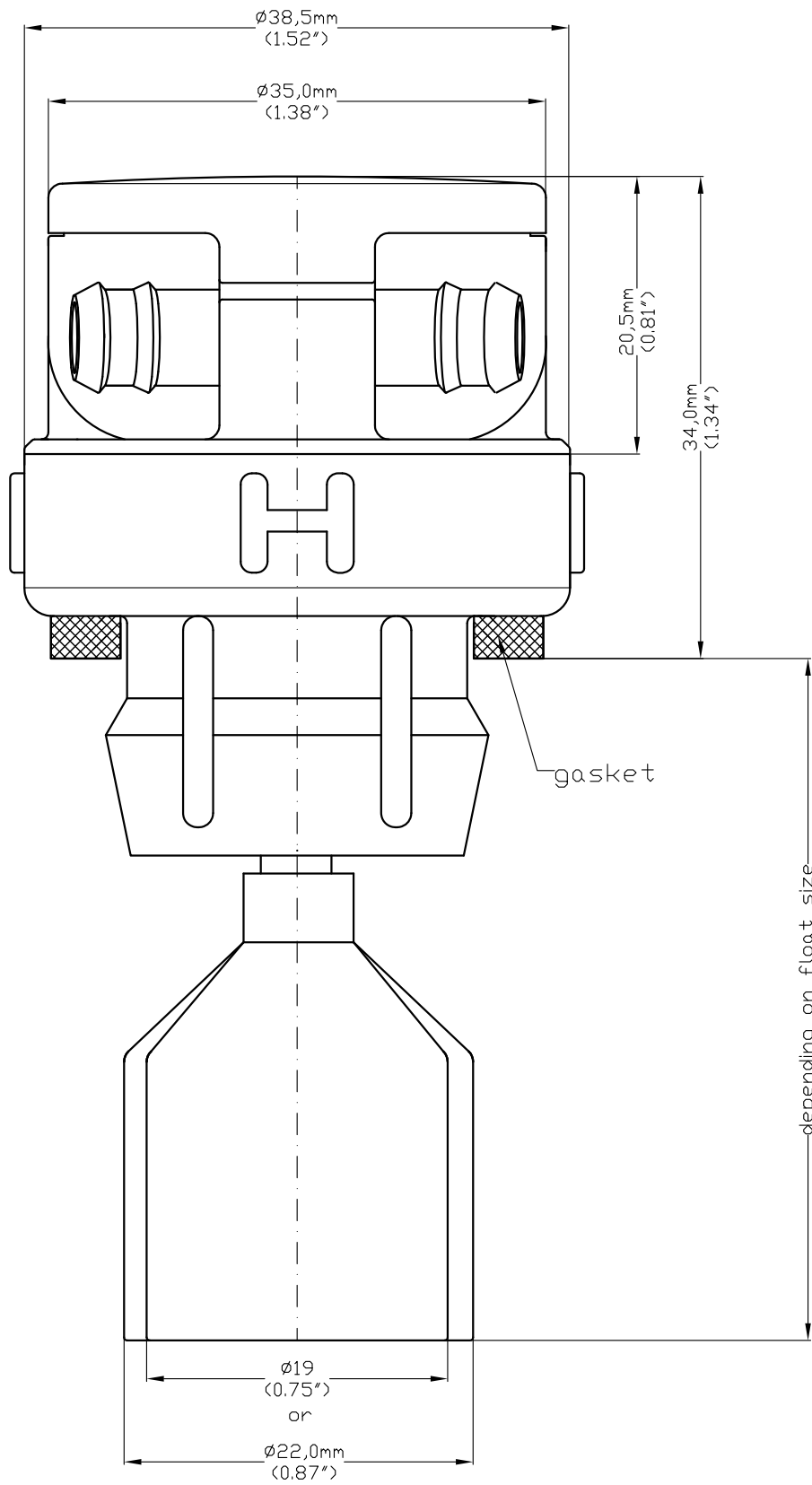

# CLIP IN Plug



					Maßstab/SCALE: 2:1
				2008 Datum Name	Werkstoff/MATERIAL:
				Bearb. 15.02. Scher	bfs Stopfen bfs plug CLIP IN
				Gepr.	
				Norm	
					Zeichnungs-Nr. / DWG NO.
					151000
					nicht tolerierte Freimaße nach DIN 16901 UNLESS OTHERWISE SPECIFIED TOLERANCING PER DIN 16901
Zust	Änderung	Datum	Name	 Ing. Klaus Oschmann Mitterweg 9 - 11 85230 Bergkirchen	