

MASSBLATT GEWINDEADAPTER (SPECIFICATIONS THREADED ADAPTERS)

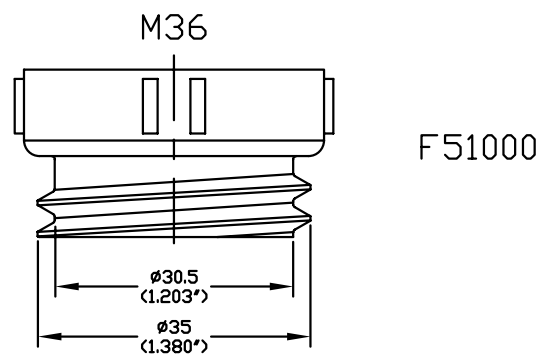
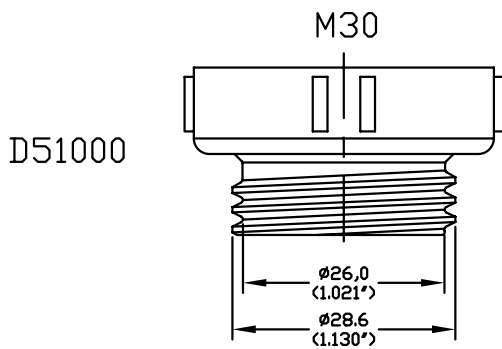
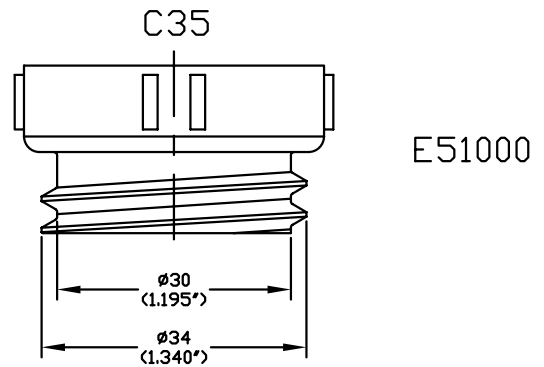
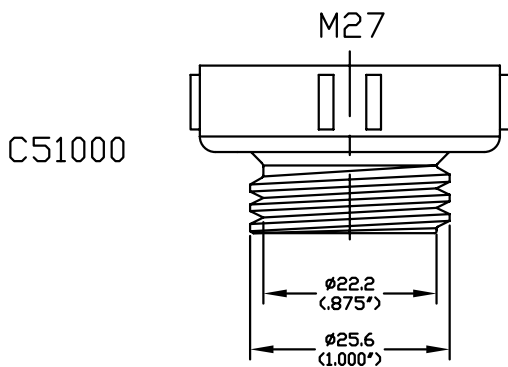

						Maßstab/SCALE:			
						1998	Datum	Name	Maßblatt für Gewindeadapter (threaded adapter)
						Bearb.	01.07.	Scher	
						Gepr.			
						Norm			
						bfs		Zeichnungs-Nr. / DWG NO.	
						ing. klaus oschmann mitterweg 9 - 11 85230 bergkirchen		09GXXX	
Zust	Änderung	Datum	Name			nicht tolerierte Freimaße nach DIN 16901 UNLESS OTHERWISE SPECIFIED TOLERANCING PER DIN 16901			